

**Bruciatori policombustibile di gasolio/gas**  
**Dual fuel Gas-Oil/Gas burners**  
**Brûleurs mixtes fioul/gaz**  
**Mehrstoffbrenner Heizöl/Gas**  
**Quemadores policombustible gasòleo / gas**

Funzionamento bistadio progressivo o modulante  
Two stage progressive or modulating operation  
Fonctionnement à 2 allures progressif ou modulant  
Zweistufig gleitender oder modulierender Betrieb  
Funcionamiento a dos llamas progresivas o modulante

COD.	MOD.	TYP
<b>3899602 - 3899612</b>	<b>RLS 500/M MX</b>	<b>1300T</b>

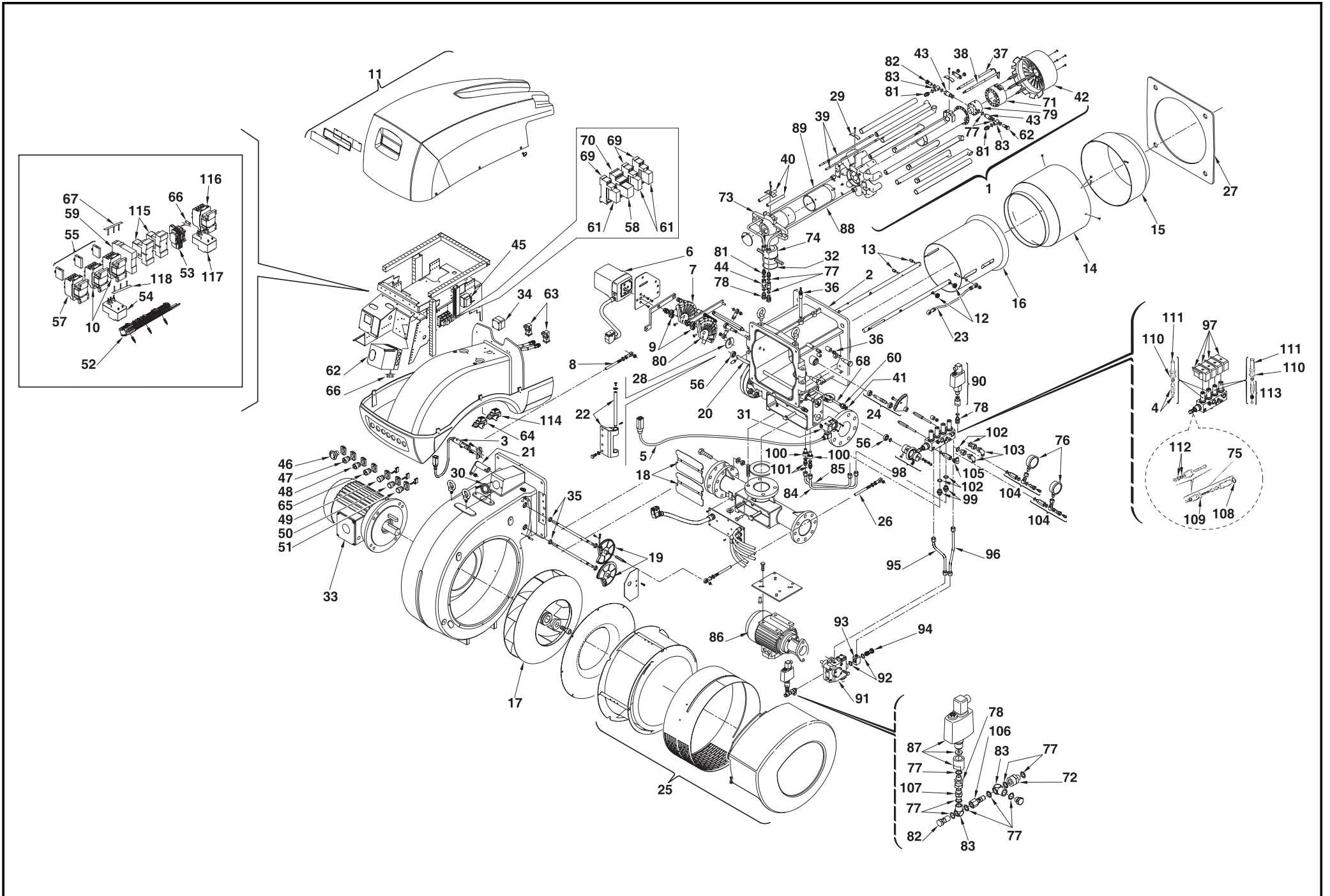

N.	COD.	DESCRIZIONE	DESCRIPTION	DESCRIPTION	BESCHREIBUNG	DENOMINACION	MATRICOLA BRUCIATORE BURNER SERIAL NUMBER MATRICULE BRULEUR BRENNER KENN-NUMMER MATRICULA QUEMADORES	*
1	3014227	TESTA GAS	GAS HEAD	TÊTE GAZ	GASKOPF	CABEZAL GAS		
2	3013639	MANICOTTO	MANIFOLD	MANCHON	GASANSCHLUSS	MANGUITO		
3	20005518	FOTOCELLULA UV	UV CELL	PHOTOCELLULE UV	UV PHOTOZELLE	FOTORESISTENCIA UV		A
4	3014198	NUCLEO	CORE	NOYAU	KERN	NÚCLEO		
5	3013303	COLLEGAMENTO PRESSOSTATO	PRESSURE SWITCH CONNECTION	CONNEXION PRESSOSTAT	DRUCKWÄCHTER VERBINDUNG	CABLES PRESOSTATO		C
6	20005519	SERVOMOTORE	SERVOMOTOR	SERVOMOTEUR	STELLMOTOR	SERVOMOTOR		B
7	3013865	CAMMA ARIA	AIR CAM	AIR CAME	LUFT-NOCKEN	EXCÉNTRICO AIRE		C
8	3014122	TIRANTE	TIE ROD	TIRANT	GESTÄNGE	TIRANTE		C
9	3013652	PERNO	SCREW	VIS CREUSE	HOHLKERNSCHRAUBE	JUNTA		C
10	3013978	CONTATTORE	CONTACTOR	CONTACTEUR	SCHÜTZ	CONTACTOR		C
11	3013310	COFANO	COVER	COFFRET	VERKLEIDUNG	ENVOLENTE		
12	3013965	PERNO	SCREW	VIS CREUSE	HOHLKERNSCHRAUBE	JUNTA		C
13	3013964	PERNO	SCREW	VIS CREUSE	HOHLKERNSCHRAUBE	JUNTA		C
14	3013641	CILINDRO	SLEEVE	CYLINDRE	ZYLINDER	CILINDRO		
15	3014200	IMBUTO FIAMMA	END CONE	EMBOUT GUEULARD	FLAMMENROHR	TUBO EXTREMO		B
16	3014199	OTTURATORE	SHUTTER	OBTURATEUR	SCHIEBER	OBTURADOR		C
17	3013962	GIRANTE	FAN	TURBINE	GEBLÄSERAD	TURBINA		C
18	3013319	SERRANDA ARIA	AIR DAMPER	VOLET	AIRLUFTKLAPPE	REGISTRO AIRE		
19	3013320	INGRANAGGIO	GEAR TRAIN	EN GRENAGE	RÄDERPAAR	ENGRANAJE		
20	3014170	ALBERO	SHAFT	PIVOT	NOCKEN	EJE		C
21	3013971	LEVA	LEVER	LEVIER	HEBEL	PALANCA		C
22	3013323	CERNIERA	HINGE	CHARNIERE	SCHARNIER	BISAGRA		
23	3013324	TIRANTE INTERNO	INTERNAL TIE ROD	TIRANT INTERIEUR	INNERES GESTÄNGE	TIRANTE INTERNO		C
24	3014204	GRUPPO LEVE	LEVER ASSEMBLY	GROUPE LEVIER	HEBEL	GRUPO LEVAS		
25	3013326	GRUPPO ASPIRAZIONE	AIR INTAKE ASSEMBLY	GROUPE ASPIRATION	ANSAUGGRUPPE	GRUPO ASPIRACION		
26	3013327	TIRANTE ESTERNO	EXTERNAL TIE ROD	TIRANT EXTERIEUR	AUSSERES GESTÄNGE	TIRANTE ESTERNO		C
27	3013675	SCHERMO	FLANGE GASKET	ECRAN THERMIQUE	FLANSCHDICHTUNG	JUNTA AISLANTE		A
28	3014195	QUADRANTE	SCALE LEVER	LEVIER DE BALANCE	SKALAHEBEL	PALANCA DE LA ESCALA		
29	3012872	CAVALLOTTO	U BOLT	CAVALIER	BÜGELBOLZEN	FIJACION ELECTRODO		
30	3008663	VETRINO	VIEWING PORT	REGARD	SCHAUGLAS	PLATINA		C
31	3012197	PRESSOSTATO GAS	GAS PRESSURE SWITCH	PRESSOSTAT GAZ	GASDRUCKWÄCHTER	PRESOSTATO GAS		B
32	3007170	O-RING	O-RING	JOINT TORIQUE	O-RING	JUNTA TÓRICA		B
33	3014224	MOTORE 12 kW	MOTOR 12 kW	MOTEUR 12 kW	MOTOR 12 kW	MOTOR 12 kW		C
34	3013449	PRESSOSTATO ARIA	AIR PRESSURE SWITCH	PRESSOSTAT AIR	LUFTDRUCKWÄCHTER	PRESOSTATO DEL AIRE		A
35	3012795	CUSCINETTO	BEARING	ROULEMENT	LAGER	COJINETE		C
36	3005447	PRESA DI PRESSIONE	PRESSURE TEST POINT	PRISE DE PRESSION	DRUCKENTNAHMESTELLE	TOMA DE PRESIÓN		C
37	3013546	ELETTRODO	ELECTRODE	ELECTRODE PORCELAINE	ELEKTRODE	ELECTRODO		A
38	3013547	ELETTRODO	ELECTRODE	ELECTRODE PORCELAINE	ELEKTRODE	ELECTRODO		A
39	3012281	COLLEGAMENTO	H.T. LEAD	CABLE H.T.	ZÜNDKABEL	CONEXIONADO		A
40	3012258	ISOLATORE	INSULATOR	PORCELAINE D'ELECTRODE	ISOLATOR	AISLADOR		A
41	3007029	O-RING	O-RING	JOINT TORIQUE	O-RING	JUNTA TÓRICA		B
42	3014171	ELICA	DISC HOLDER	SUPPORT DE L'ACCROCHE FLAMME	STAUSCHEIBENHALTERUNG	SOPORTE ESTABILIZADOR		A
43	3013460	RACCORDO	CONNECTOR	MAMELON	NIPPEL	RACORD		C
44	3013461	VALVOLA NON RITORNO	VALVE NOT RETURN	VANNE PAS RETOUR	RÜCKSCHLAGVENTIL	VALVOLA NO DE VUELTA		B
45	3012488	TRASFORMATORE	TRANSFORMER	TRANSFORMATEUR	ZÜNDTRANSFORMATOR	TRANSFORMADOR		B
46	3013333	PULSANTE EMERGENZA	EMERGENCY PUSH-BUTTON	BOUTON ARRÊT D'URGENCE	NOTSOPTASTE	BOTÓN DE EMERGENCIA		C
47	3013334	SELETTORE AUTO/MAN	SWITCH AUTO/MAN	SÉLECTEUR AUTO/MAN	SCHALTER AUTO/MAN	SELECCIÓN AUTO/MAN		C
48	3013335	SELETTORE +/-	SWITCH +/-	SÉLECTEUR +/-	SCHALTER +/-	SELECTIVO +/-		C
49	3013366	INDICAT. LUM. VERDE	GREEN SIGNAL LIGHT	SIGNAL LUMINEUX VER	GRÜNE LEUCHTANZEIGE	INDIC. LUMINOSO VERDE		A

N.	COD.	DESCRIZIONE	DESCRIPTION	DESCRIPTION	BESCHREIBUNG	DENOMINACION	MATRICOLA BRUCIATORE BURNER SERIAL NUMBER MATRICULE BRULEUR BRENNER KENN-NUMMER MATRICULA QUEMADORES	*
50	3013353	INDICATORE LUM. ROSSO	RED SIGNAL LIGHT	SIGNAL LUMINEUX ROUGE	ROTE LEUCHTANZEIGE	INDIC. LUMINOSO ROJO		A
51	3013354	PULS. LUMINOSO ROSSO DI RESET	RED RESET PUSH-BUTTON	BOUTON ROUGE DE RESET	ROTER KNOPF FÜR RESET	BOTÓN LUMINOSO ROJO DE RESET		C
52	3014225	MORSETTIERA	TERMINAL STRIP	PLAQUE À BORNES	KLEMMENBRETT	REGLETA CONEXIONE		
53	3013359	MORSETTIERA AUSILIARIA	AUXILIARY TERMINAL STRIP	PLAQUE À BORNES AUXILIAIRE	HILFSKLEMMENBRETT	REGLETA CONEXIONES AUXILIARIA		
54	20005524	RELÈ TERMICO	OVERLOAD	RELAIS TERMIQUE	ÜBERSTROMAUFLÖSER	RELÉ TÉERMICO		C
55	3012783	CONTATTO AUSILIARIO	AUXILIARY CONTACT	CONTACTES AUXILIARE	HILFSKONTAKT	CONTACTO AUXILIAR		B
56	3013650	CUSCINETTO	BEARING	ROULEMENT	LAGER	COJINETE		C
57	3013979	CONTATTORE	CONTACTOR	CONTACTEUR	SCHÜTZ	CONTACTOR		C
58	3012368	RELÈ	RELAY	RELAIS	RELAIS	RELÉ		
59	3012785	TEMPORIZZATORE	TIMER	TEMPORISATEUR	ZEITRELAIS	RETARDATOR		B
60	3013653	RACCORDO	CONNECTOR	MAMELON	NIPPEL	RACORD		C
61	3012842	RELÈ	RELAY	RELAIS	RELAIS	RELÉ		C
62	3006090	APPARECCHIATURA LFL	CONTROL BOX LFL	BOITE DE CONTROLE LFL	STEUERGERÄT LFL	CAJA CONTROL LFL		B
63	3013363	PRESA 7 POLI 90°	7 POLE SOCKET 90°	PRISE 7 POLES 90°	STECKERBUCHSE 7 POLE 90°	CONEC. MACHO DE 7 CONTACTOS 90°		
64	3013364	PRESA 17 POLI	17 POLE SOCKET	PRISE 17 POLES	STECKERBUCHSE 17 POLE	CONEC. MACHO DE 17 CONTACTOS		
65	3013474	SELETTORE GAS/OLIO	SWITCH GAS/OIL	SÉLECTOR GAZ/OIL	SCHALTER GAS/ÖL	SELECTIVO GAS/OLEO		C
66	3014106	FUSIBILE 6,3 A	FUSE 6.3 A	FUSIBLE 6,3 A	SCHMELZSICHERUNG 6,3 A	FUSIBLE 6,3 A		
67	20005522	CONNESSIONI STELLA /TRIANGOLO	STAR / DELTA POWERED CONNECTIONS	CONNEXIONS ÉTOILE / TRIANGLE	STERN / DREIECK VERBINDUNGEN	CONEXIONES ESTRELLA / TRIÁNGULO		
68	3014172	ALBERO	SHAFT	PIVOT	NOCKEN	EJE		C
69	3012841	ZOCCOLO	BASE	SOCLE	SOCKEL	ZOCALO		C
70	3003935	ZOCCOLO	BASE	SOCLE	SOCKEL	ZOCALO		C
71	3014201	TAZZA	AIR DIFFUSER	DIFFUSEUR D'AIR	STAUSCHEIBE	DIFUSOR DEL AIRE		C
72	3003589	RACCORDO	CONNECTOR	MAMELON	NIPPEL	RACORD		C
73	3014118	GOMITO	ELBOW	COUDE	GASSCHLITTEN	CODO		
74	3014117	VOLANTINO	CONTROL WHEEL	ROUE DE CONTROLE	REGELRAD	RUEDA DE CONTROL		
75	3014173	GRUPPO REGOLATORE	REGULATOR	GROUPE RÉGULATEUR	REGLERGRUPPE	CONJUNTO REGULADOR		
76	3006140	MANOMETRO	GAUGE	MANOMÈTRE	DRUCKMESSER	MANÓMETRO		
77	3007079	GUARNIZIONE	GASKET	JOINT	DICHTUNG	JUNTA		
78	3013462	RACCORDO	CONNECTOR	MAMELON	NIPPEL	RACORD		
79	3014228	POLVERIZZATORE	SPRAY NOZZLE	BUSE D'INJECTION GICLEUR	EINSPRITZDÜSE	PULVERIZADOR		
80	3012864	CAMMA GAS	GAS CAM	GAZ CAME	GAS-NOCKEN	EXCÉNTRICO GAS		
81	3012549	RACCORDO	CONNECTOR	MAMELON	NIPPEL	RACORD		C
82	3003006	PERNO	SCREW	VIS CREUSE	HOHLKERNSCHRAUBE	JUNTA		C
83	3012455	RACCORDO	CONNECTOR	MAMELON	NIPPEL	RACORD		C
84	3014174	TUBO	PIPE	TUYAU	ROHR	TUBO		
85	3014175	TUBO	PIPE	TUYAU	ROHR	TUBO		
86	3012283	MOTORE POMPA	PUMP MOTOR	MOTEUR POMPE	PUMPENMOTOR	MOTOR BOMBA		
87	3014167	PRESSOSTATO OLIO MIN.	MIN. OIL PRESSURE SWITCH	PRESSOSTAT HUILE MIN.	MIN. ÖLDRUCKWÄCHTER	PRESOSTATO ACEITE PARA MÍNIMA		
88	3014202	TUBO	PIPE	TUYAU	ROHR	TUBO		
89	3014203	TUBO	PIPE	TUYAU	ROHR	TUBO		
90	3014180	PRESSOSTATO OLIO MAX.	MAX. OIL PRESSURE SWITCH	PRESSOSTAT HUILE MAX.	MAX. ÖLDRUCKWÄCHTER	PRESOSTATO ACEITE PARA MÁXIMA		
91	3006410	POMPA	PUMP	POMPE	PUMPE	BOMBA		
92	3007164	GUARNIZIONE	GASKET	JOINT	DICHTUNG	JUNTA		
93	3003055	RACCORDO	CONNECTOR	MAMELON	NIPPEL	RACORD		C

N.	COD.	DESCRIZIONE	DESCRIPTION	DESCRIPTION	BESCHREIBUNG	DENOMINACION	MATRICOLA BRUCIATORE BURNER SERIAL NUMBER MATRICULE BRULEUR BRENNER KENN-NUMMER MATRICULA QUEMADORES	*
94	3006184	PERNO	SCREW	VIS CREUSE	HOHLKERNSCHRAUBE	JUNTA		C
95	3014176	TUBO	PIPE	TUYAU	ROHR	TUBO		
96	3014177	TUBO	PIPE	TUYAU	ROHR	TUBO		
97	3003001	BOBINA	COIL	BOBINE	SPULE	BOBINA		
98	3003186	CUSCINETTO	BEARING	PALIER	LAGER	COJINETE		
99	3009084	RACCORDO	CONNECTOR	MAMELON	NIPPEL	RACORD		C
100	3013557	RACCORDO	CONNECTOR	MAMELON	NIPPEL	RACORD		C
101	3012549	RACCORDO	CONNECTOR	MAMELON	NIPPEL	RACORD		C
102	3007082	GUARNIZIONE	GASKET	JOINT	DICHTUNG	JUNTA		
103	3014178	RACCORDO	CONNECTOR	MAMELON	NIPPEL	RACORD		C
104	3013998	RACCORDO	CONNECTOR	MAMELON	NIPPEL	RACORD		C
105	3014179	RACCORDO	CONNECTOR	MAMELON	NIPPEL	RACORD		C
106	3005804	PERNO	SCREW	VIS CREUSE	HOHLKERNSCHRAUBE	JUNTA		C
107	3009046	RACCORDO	CONNECTOR	MAMELON	NIPPEL	RACORD		C
108	3003201	O-RING	O-RING	JOINT TORIQUE	O-RING-DICHTUNG	JUNTA TÓRICA		
109	3003204	O-RING	O-RING	JOINT TORIQUE	O-RING-DICHTUNG	JUNTA TÓRICA		
110	3007081	GUARNIZIONE	GASKET	JOINT	DICHTUNG	JUNTA		
111	3014196	GUAINA	SHEATH	GAINÉ	HÜLSE	VAINA		
112	3003203	O-RING	O-RING	JOINT TORIQUE	O-RING-DICHTUNG	JUNTA TÓRICA		
113	3014197	NUCLEO	CORE	NOYAU	KERN	NÚCLEO		
114	3013473	PRESA 8 POLI	8 POLE SOCKET	PRISE 8 POLES	STECKERBUCHSE 8 POLE	CONEC. MACHO DE 8 CONTACTOS		A
115	20005520	RELÈ + ZOCCOLO	RELAY + BASE	RELAIS + SOCLE	RELAIS + SOCKEL	RELÉ + ZOCALO		
116	20005525	CONTATTORE	CONTACTOR	CONTACTEUR	SCHÜTZ	CONTACTOR		C
117	20005527	RELÈ TERMICO	OVERLOAD	RELAIS THERMIQUE	ÜBERSTROMAUSLÖSER	RELÉ TERMICO		C

\*

**RICAMBI CONSIGLIATI - ADVISED PARTS - RECHANGE CONSEIL - EMPFOHLENE ERSATZTEILE - RECAMBIOS ACONSEJADOS**

A = Ricambi per dotazione minima - Spare parts for minimum fittings - Pièces détachées pour équipement minimum - Ersatzteile für minimale Ausstattung - Recambios para equipamiento mínimo

A+B = Ricambi per dotazione base di sicurezza - Spare parts for basic safety fittings - Pièces détachées pour équipement standard de sécurité - Ersatzteile für Sicherheitsgrundausrüstung - Recambios para equipamiento básico de seguridad

A+B+C = Ricambi per dotazione estesa di sicurezza - Spare parts for extended safety fittings - Pièces détachées pour équipement complet de sécurité - Ersatzteile für erweiterte Sicherheitsausstattung - Recambios para equipamiento general de seguridad





---

**RIELLO**

RIELLO S.p.A.  
I-37045 Legnago (VR)  
Tel.: +39.0442.630111  
[http:// www.riello.it](http://www.riello.it)  
[http:// www.rielloburners.com](http://www.rielloburners.com)